

LED INDUSTRY KIT GEN. 3

WU-M-600-S2



LED INDUSTRY KIT GEN. 3

WU-M-600-S2

Typical Applications

Built-in luminaires/general illumination

- Industry lighting for:
 - Production halls
 - Warehouses
- Lighting for sports facilities
- Lighting for department stores



LED Industry Kit Gen. 3

- **LONG SERVICE LIFE TIME: >54,000 HRS. (L90/B10)**
- **HIGHLY EFFICIENT: UP TO 193 LM/W
AT T_p = 50 °C**
- **FLEXIBLE LIGHT DISTRIBUTION
BY THREE DIFFERENT OPTICS**
- **ENEC AND VDE APPROVED**



LED Industry Kit Gen. 3



Technical Notes

- LED built-in module for integration into luminaires
- Dimensions: 289x55 mm
- Driving current: 350 mA / 500 mA / 700 mA / 1050 mA
- On-board push terminal system
- Colour tolerance: 3-step MacAdam

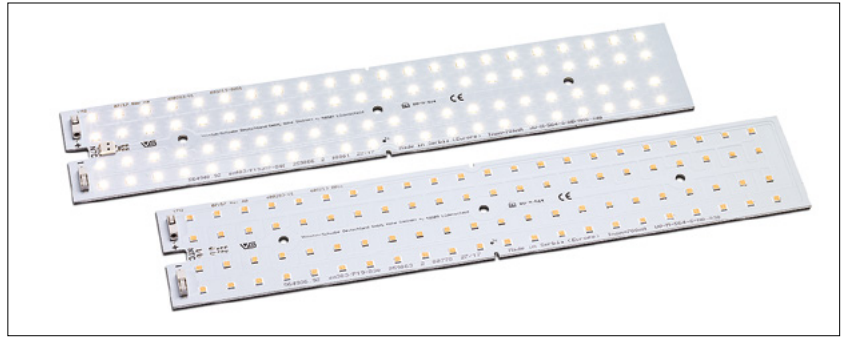

Electrical Characteristics

at $t_p = 50\text{ °C}$

Type	No. of LEDs	Typ. voltage DC				Typ. power consumption			
		350 mA V	500 mA V	700 mA V	1050 mA V	350 mA W	500 mA W	700 mA W	1050 mA W
WU-M-600-S2	88	60.7	62.3	64.3	67.5	21.2	31.1	45	70.9

Voltage and power consumption tolerance: $\pm 10\%$

Use of external LED constant current driver required.

Maximum Ratings

Exceeding the maximum ratings can lead to reduction of service life or destruction of the module.

Type	Operating current mA	Operation temperature range at t_c point		Storage temperature range		Max. allowed repetitive peak current mA
		$^{\circ}\text{C}$ min.	$^{\circ}\text{C}$ max.	$^{\circ}\text{C}$ min.	$^{\circ}\text{C}$ max.	
WU-M-600-S2	350	-30	+85	-30	+85	1600
	500	-30	+85	-30	+85	1600
	700	-30	+85	-30	+85	1600
	1050	-30	+85	-30	+85	1600

Operating Life

in hours at measured temperature at t_p point

	350 mA			500 mA			700 mA			1050 mA		
	40 $^{\circ}\text{C}$	50 $^{\circ}\text{C}$	85 $^{\circ}\text{C}$	40 $^{\circ}\text{C}$	50 $^{\circ}\text{C}$	85 $^{\circ}\text{C}$	40 $^{\circ}\text{C}$	50 $^{\circ}\text{C}$	85 $^{\circ}\text{C}$	40 $^{\circ}\text{C}$	50 $^{\circ}\text{C}$	85 $^{\circ}\text{C}$
L90/B10	> 54,000	> 54,000	> 54,000	> 54,000	> 54,000	51,000	> 54,000	> 54,000	51,000	> 54,000	> 52,000	> 45,000
L80/B10	> 54,000	> 54,000	> 54,000	> 54,000	> 54,000	> 54,000	> 54,000	> 54,000	> 54,000	> 54,000	> 54,000	> 54,000
L70/B10	> 54,000	> 54,000	> 54,000	> 54,000	> 54,000	> 54,000	> 54,000	> 54,000	> 54,000	> 54,000	> 54,000	> 54,000
L90/B50	> 54,000	> 54,000	> 54,000	> 54,000	> 54,000	> 54,000	> 54,000	> 54,000	> 54,000	> 54,000	> 54,000	> 54,000
L80/B50	> 54,000	> 54,000	> 54,000	> 54,000	> 54,000	> 54,000	> 54,000	> 54,000	> 54,000	> 54,000	> 54,000	> 54,000
L70/B50	> 54,000	> 54,000	> 54,000	> 54,000	> 54,000	> 54,000	> 54,000	> 54,000	> 54,000	> 54,000	> 54,000	> 54,000

The values contained in this data sheet can change due to technical innovations. Any such changes will be made without separate notification.

LED Industry Kit Gen. 3

Optical Characteristics

at $t_p = 50\text{ }^\circ\text{C}$; without secondary optics

Type	Ref. No.	Colour	Correlated colour temperature (K)	Typ. luminous flux* (lm) and efficiency* (lm/W) at								Beam angle °	Min. CRI R_a	Photo-metric code
				350 mA		500 mA		700 mA		1050 mA				
				lm	lm/W	lm	lm/W	lm	lm/W	lm	lm/W			
WU-M-600-S2-830	569999	warm white	3000	3825	180	5365	172	7365	163	10675	150	120	80	830/349
WU-M-600-S2-840	570000	neutral white	4000	4095	193	5745	184	7885	175	11430	161	120	80	840/349
WU-M-600-S2-850	570001	cool white	5000	4065	191	5700	183	7825	174	11335	160	120	80	850/349
WU-M-600-S2-865	570002	cool white	6500	3860	182	5410	174	7430	165	10765	152	120	80	865/349

* Production tolerance of luminous flux and efficiency: $\pm 10\%$ | Assembly option with NTC interface on-board (available on request)

Mechanical Dimensions SMD PCB

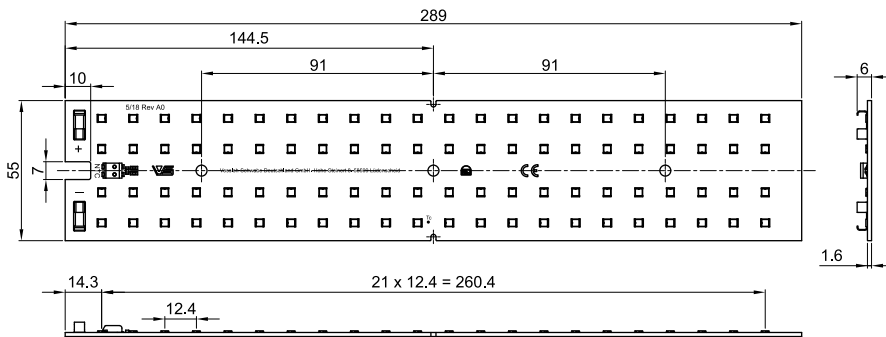

- The number of modules that can be connected in series depends on the available output voltage of the LED driver.
- The clearance and creepage distances are designed for working voltages up to 450 V DC (basic insulation) and 229 V DC (reinforced insulation).

Bins

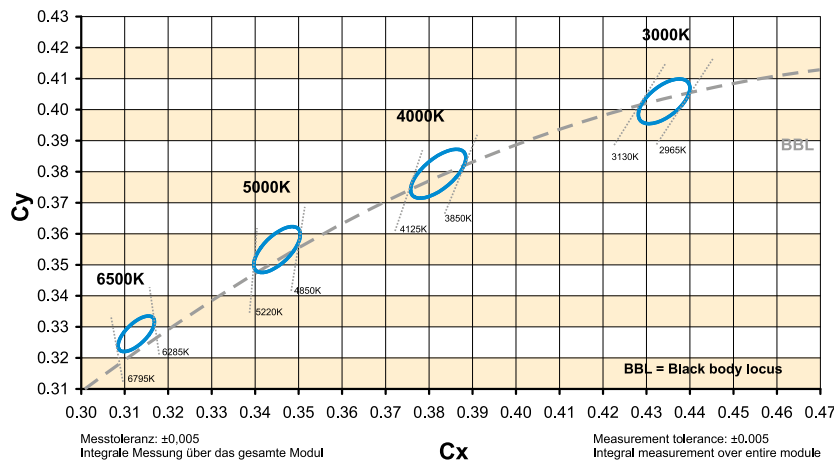

The values contained in this data sheet can change due to technical innovations. Any such changes will be made without separate notification.

LED Industry Kit Gen. 3

Technical Notes for Optics

- Brilliant light distribution and surfaces
- Highly efficient up to 92%
- Material: PC, transparent
- Suitable for luminaires with impact rating IK08/5J
- Degree of protection: IP65 (incl. silicone gasket)
- Dimensions (LxWxH): 318x84x11.75 mm
- Max. allowed temperature: 100 °C
- Fixing holes for M4 screws



Light distribution	Optics type	Ref. No.	Efficiency %	Weight g
Wide 60°	97600	565228	92	190
Wide 90°	97601	565229	92	178
High Rack	97602	565230	92	173

Material PMMA on request

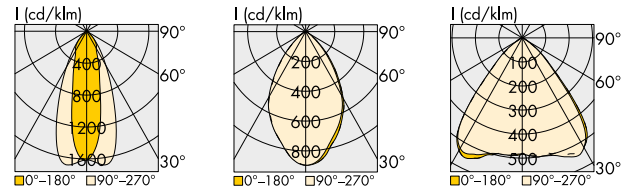

High Rack

Wide 60°

Wide 90°

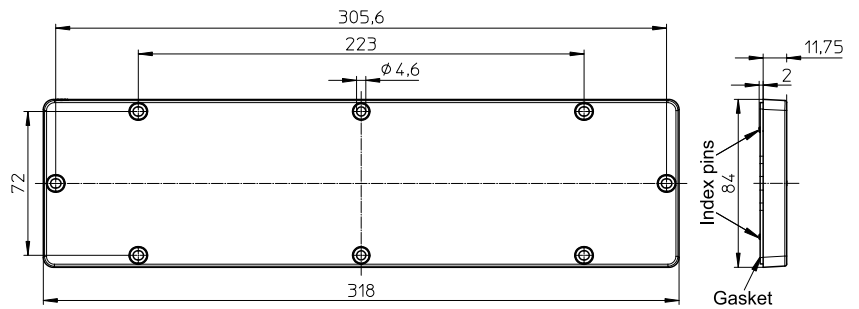

The values contained in this data sheet can change due to technical innovations. Any such changes will be made without separate notification.

LED Industry Kit Gen. 3

Heat Sink for LED Industry Kit

Under no circumstances may heat sinks ever be covered by insulation material or similar. Air ventilation must be ensured.

Technical Notes for Heat Sink

Material: aluminium EN AW-6060 (AlMgSi 0,5)

T66 anodized

Fixing holes for PCB: for self-tapping screws M4, screw length: 6 mm

Fixing holes for optics: for self-tapping screws M4, screw length: 12 mm

2 additional blind holes for holding the index pins of the optics for easier positioning of the optics on the heat sink

Centrally located cable bushing with an M16x1,5 thread for an IP65 cable gland

Heat sink optimized for operating currents

up to 700 mA

at max. ambient temperature t_a 50 °C

Dimensions (LxWxH): 320x92x48.25 mm

Weight: 1050 g, Packaging unit: 1 pcs.

Ref. No.: 566638

Heat sink optimized for operating currents

up to 1050 mA

at max. ambient temperature t_a 50 °C

Dimensions (LxWxH): 320x122x70 mm

Weight: 2260 g, Packaging unit: 1 pcs.

Ref. No.: 569382



566638

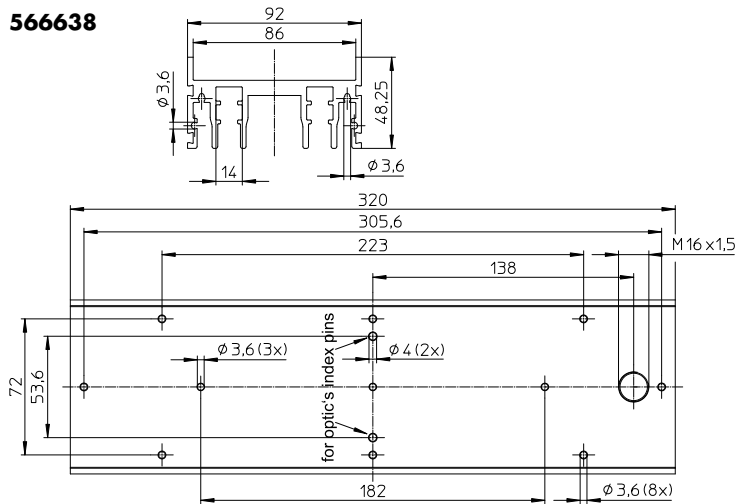

569382

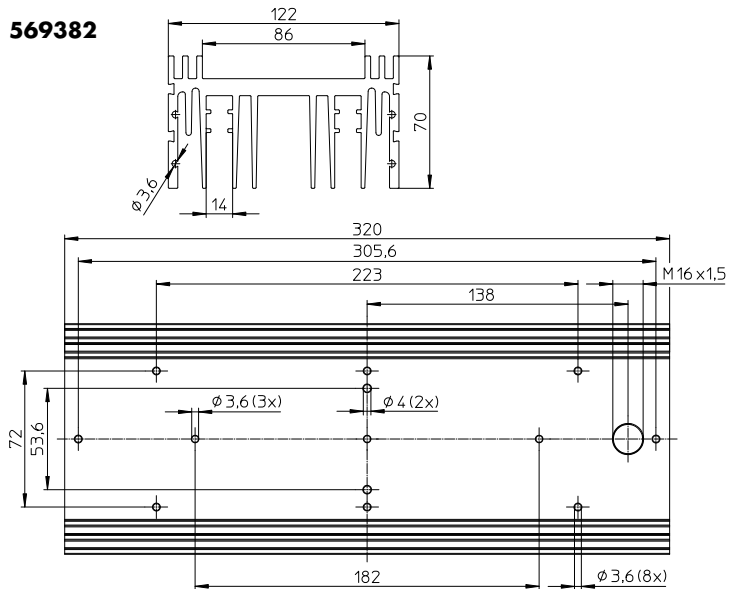

The values contained in this data sheet can change due to technical innovations. Any such changes will be made without separate notification.

LED Industry Kit Gen. 3

Industry Kit Installation Instructions

Step 1

The LED PCB must be placed on and fixed to the heat sink.
Please only ever use flat-headed M4x6 screws.
Maximum torque on screws: 1.4 Nm

Step 2

Establish electrical contact by feeding the stripped leads through the screw hole of the PG port and inserting them into the push-in terminals of the LED PCB. Correct polarity must be ensured when establishing a connection to the LED driver.

Step 3

Now place the optics on the PCB and apply pressure to the middle of the optics to that all the ribs in the middle and the end of the optics align with the spaces in the LED PCB. After first tightening the two M4x12 screws in the middle of the optics, attach the optics itself to the heat sink using six M4x12 screws.

Torque on screws: 0.8–1 Nm for M4x12 self-cutting screws in accordance with DIN 7500. With regard to the heat sink, the permissible torque may differ depending on the screw used and the the kind of borehole.

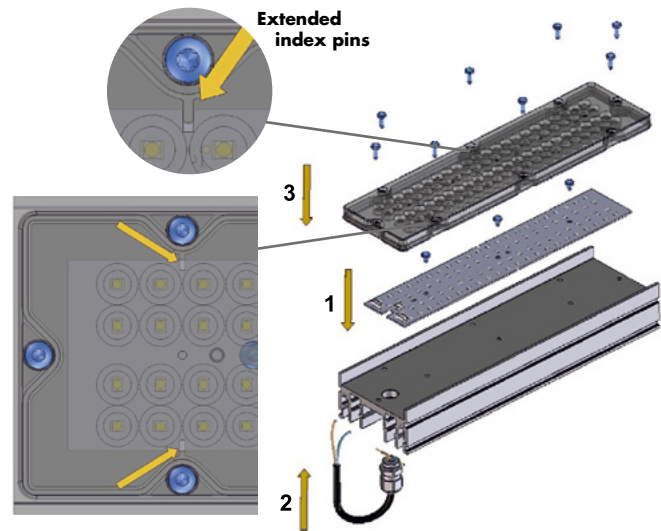

LED Industry Kit Gen. 3 – Assembly Unit

Technical Notes for assembled Industry Kit

Equipped with PCB WU-M-600-S2, optics with silicone gasket and heat sink with cable thread fitting ST M16x1.5 mm (max. tightening torque: 3 Nm) and connected leads 2x1 mm², usable lead length: 320 mm

Fixation: via a groove running on both sides

Degree of protection: IP65

Assembly unit 700 mA

Dimensions (LxWxH): 320x92x48.25 mm

Weight: 1350 g, packaging unit: 1 pcs.

Light distribution	Optics type	Ref. No.	Correlated colour temperature (K)
Wide 60°	97610	570098	3000
Wide 60°	97610	570099	4000
Wide 60°	97610	570100	5000
Wide 60°	97610	570101	6500
Wide 90°	97611	570102	3000
Wide 90°	97611	570103	4000
Wide 90°	97611	570104	5000
Wide 90°	97611	570105	6500
High Rack	97612	570106	3000
High Rack	97612	570107	4000
High Rack	97612	570108	5000
High Rack	97612	570109	6500

Assembly unit 1050 mA

Dimensions (LxWxH): 320x122x70 mm

Weight: 2560 g, packaging unit: 1 pcs.

Light distribution	Optics type	Ref. No.	Correlated colour temperature (K)
Wide 60°	97620	571208	3000
Wide 60°	97620	571209	4000
Wide 60°	97620	571210	5000
Wide 60°	97620	571211	6500
Wide 90°	97621	571224	3000
Wide 90°	97621	571226	4000
Wide 90°	97621	571227	5000
Wide 90°	97621	571228	6500
High Rack	97622	571229	3000
High Rack	97622	571230	4000
High Rack	97622	571231	5000
High Rack	97622	571232	6500

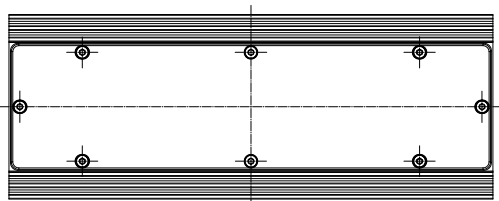
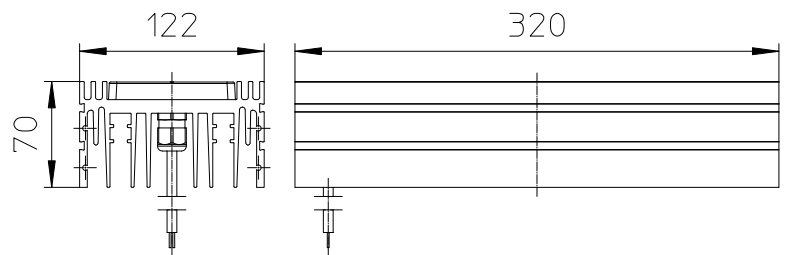
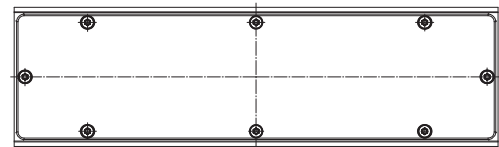
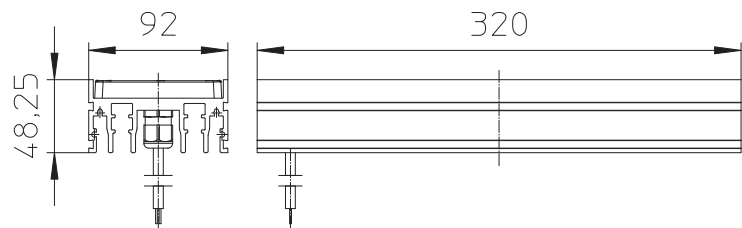

The values contained in this data sheet can change due to technical innovations. Any such changes will be made without separate notification.

Accessories for LED Industry Kit

Driver Box

Casing for a driver and fixing the installed Industry Kit Assembly Unit

Material: aluminium EN AW-6060 T66

Dimensions: 320x149.25x65.25 mm

(other casing lengths on request)

Weight: 1080 g

Packaging unit: 1 pcs.

Ref. No.: 567836

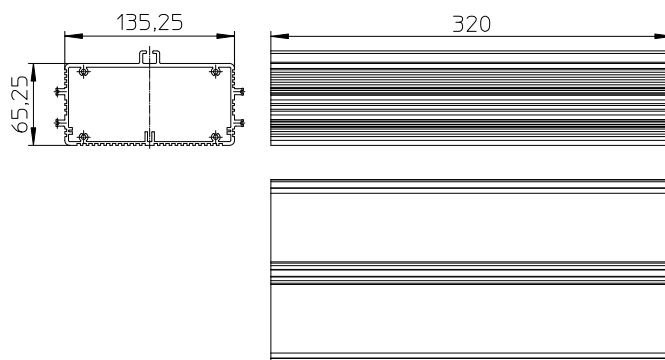

End Cap

For lateral closure of the driver box

Material: PC

Dimensions: 135.25x65.25x8 mm

Fixation: 4 fixing holes for screws M4

Weight: 30 g

Packaging unit: 100 pcs.

Ref. No.: 566640

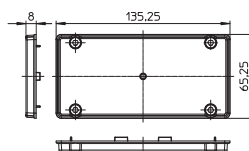

Gasket for End Cap

O-ring for degree of protection IP65

Material: silicone

Dimensions: 135.25x62.25x1.8 mm

Weight: 10 g

Packaging unit: 100 pcs.

Ref. No.: 566850

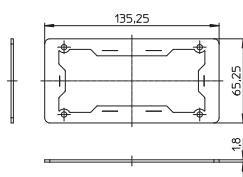

Mounting of end caps with gasket to the driver box

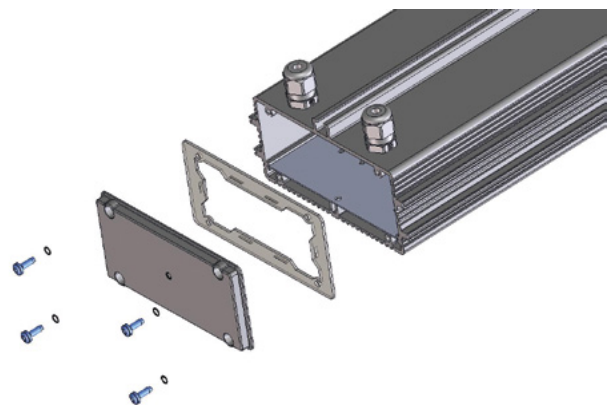

The values contained in this data sheet can change due to technical innovations. Any such changes will be made without separate notification.

LED Industry Kit Gen. 3

Assembly and Safety Information

Installation must be carried out under observation of the relevant regulations and standards. The LED modules are designed for operation within a casing or luminaire. Installation must be carried out in a voltage-free state (i.e. disconnection from the mains). The following advice must be observed; non-observance can result in the destruction of the LED assembly modules, fire and/or other hazards.

- Consider safety regulations acc. EN 60598 in the luminaire design, especially when the operating LED driver is not galvanic isolated.
 - In mode of operation regard to sufficient isolation.
 - Live parts must not be touched in operation mode.  Danger in life!!!
- ESD (electrostatic discharge) protection measures must be observed when handling and installing the LED modules. See VS's application notes on ESD protection.
- Adequate anti-static electricity measures, including the use of conductive shoes, ionizers, work bench grounding, wrist straps, flooring and stools could be used.
- LED assembly modules must not be subjected to any undue mechanical stress, e. g.:
 - do not treat as bulk cargo
 - avoid shear and compressive forces during handling and installation
 - do not damage circuit paths
 - avoid any pressure on the light emitting surface
- Safe operation only possible by the use of external constant current sources (I_{max} . see table "Electrical Characteristics").
- Operation only with power supply units that feature the following protection:
 - Short-circuit protection
 - Overload protection
 - Overheating protection
- The module can be fixed with M4 screws. Fixation only with flat or cylinder head screws (M4) (no countersank screws)
Max. torque: 1.2 Nm (M4)
- Please ensure the correct polarity of the leads prior to commissioning. Reversed polarity can destroy the modules.
- Safety regulations acc. to EN 60598 (or further standards) has to be observed if the maximum output voltage exceed the permitted touchable value.
- Measurement tolerances:
 - luminous flux: $\pm 7\%$
 - voltage: $\pm 3\%$
 - CRI: ± 1
- The following points must be observed when connecting LED modules in parallel:
 - All LED strings that are wired in parallel must contain the same number of LEDs (symmetrical loading).
 - Owing to differing forward biases, there can be a difference of up to 10% in brightness between modules connected in parallel.
- To ensure problem-free operation, the specified maximum temperature at the t_p point (see "Operating Life") must be observed (and measured in accordance with EN 60598-1). To satisfy this point, it may be necessary to put measures in place to ensure any heat is dissipated from the PCB to the environment.

- In the event of outdoor applications or applications in damp locations, care must be taken to protect LED assembly modules against humidity, splashes and jets of water. Any corrosion damage resulting from humidity or contact with condensation will not be recognised as a defect or manufacturing fault. LED assembly modules are not specially protected against foreign bodies or dust. Depending on the type of application, further protection must be ensured to prevent dust and foreign bodies from entering.
- Due to the manufacturing process, the PCBs of the LED assembly modules can have sharp edges and corners. Care must therefore be taken during handling and installation to avoid injury.
- For optimal load of used constant current driver the modules can only be connected in series. The quantity of LED modules is limited by the sum of forward voltage and the capacity of used constant current driver. Safety regulations acc. to EN 60598 has to be observed if the sum of forward voltage exceed the permitted touchable value.
- Operating LED modules in the presence of certain chemical substances or in chemically enriched (aggressive) environments can impair module functionality or even cause total module failure. Detailed information can be found in our "Chemical Incompatibility" PDF on our website www.vossloh-schwabe.com
- The photobiological safety of the LED modules must be classified into risk groups in accordance with EN 62471
Rating in accordance with IEC / TR 62778: risk group 1 as long as subsequent table is fulfilled:

Type	CCT	Max. operating current for risk group 1 mA	E threshold for higher operating currents to be risk group 1 (lx)
WU-M-600-S2	≤ 4000	1125	≤ 1130
	5000	930	≤ 928
	6500	730	≤ 773

Applied Standards

EN 62031

LED modules for general lighting – Safety specifications



EN 62471

Photobiological safety of lamps and lamp systems

Product Guarantee

- 5 years
- The conditions for the Product Guarantee of the Vossloh-Schwabe Group shall apply as published on our homepage (www.vossloh-schwabe.com). We will be happy to send you these conditions upon request.

The values contained in this data sheet can change due to technical innovations. Any such changes will be made without separate notification.