

ALULED IP20 / IP67 HORTICULTURE

LED MODULES
IN FLAT ALUMINIUM PROFILE



ALULED IP20 / IP67 HORTICULTURE

Purple Lime

To achieve best performance of yields and nutrient concentrations of leafy greens.



AluLED IP20 / IP67 Horticulture

- ALUMINIUM PROFILE WITH HIGH QUALITY LEDs
- PLUG & PLAY DUE TO PRE-WIRED CONNECTORS
- OPTIMUM FOR LIGHTING OF PLANTS
- SLIM AND FLAT DESIGN
- INTEGRATED HEAT SINK FOR OPTIMAL THERMAL MANAGEMENT
- 5 YEARS WARRANTY
Further infos see www.vossloh-schwabe.com
- MADE IN GERMANY



AluLED IP20/IP67 Horticulture

Technical notes

Voltage supply: 48 V DC $\pm 5\%$
 Beam angle: 115°
 Allowed ambient temperature t_a : -20 to 40 °C
 Allowed storage temperature: -40 to 85 °C
 Degree of protection: IP20 or IP67
 (connectors: IP67)
 Maximum bridging current load: 3 A
 Lumen maintenance: L70/B10 (> 60,000 hrs.)
 at $t_p/t_c = 85$ °C
 ESD protection: up to 2 kV
 Packaging unit: 20 pcs. including
 mounting clips (brackets) and screws

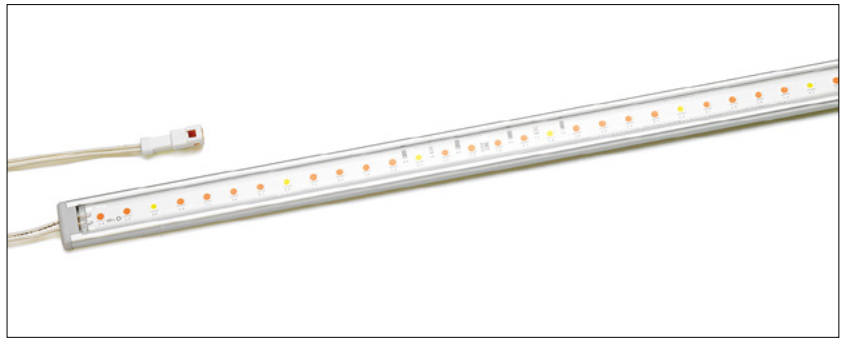

RoHS

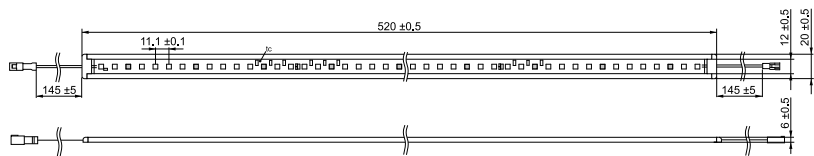
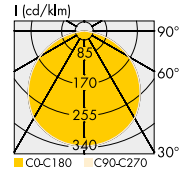

Optical characteristics

at $t_p = 50$ °C

Type	Ref. No.	Length mm	No. of LEDs	Current mA	Colour temperature K	Luminous flux* lm	Typ. power W	Typ. photon flux and efficiency at			
								PAR (400–700 nm)		PBAR (360–800 nm)	
								$\mu\text{mol/s}$	$\mu\text{mol/J}$	$\mu\text{mol/s}$	$\mu\text{mol/J}$
IP20											
AluLED-520-HC-IP20-purple(25%blue)+lime	571383	520	45	360	2700	1197	17.3	28.26	1.65	31.55	1.84
AluLED-520-HC-IP20-purple(12.5%blue)+lime	571384	520	45	360	2096	1174	17.3	26.98	1.56	30.83	1.79
AluLED-520-HC-IP20-purple(2.5%blue)+lime	571385	520	45	360	1861	1062	17.3	25.00	1.45	29.40	1.71
IP67											
AluLED-520-HC-IP67-purple(25%blue)+lime	571370	520	45	360	12147	1108	17.3	27.42	1.59	29.86	1.73
AluLED-520-HC-IP67-purple(12.5%blue)+lime	571371	520	45	360	2415	1116	17.3	25.71	1.50	28.87	1.69
AluLED-520-HC-IP67-purple(2.5%blue)+lime	571372	520	45	360	1911	1008	17.3	23.11	1.35	26.82	1.56

* Production tolerance for luminous flux: $\pm 10\%$ | Further lengths on request

Die Werte in diesem Datenblatt können sich aufgrund technischer Innovationen verändern und werden ohne gesonderte Benachrichtigung vorgenommen.

Spektrale Eigenschaften

AluLED IP20 Horticulture

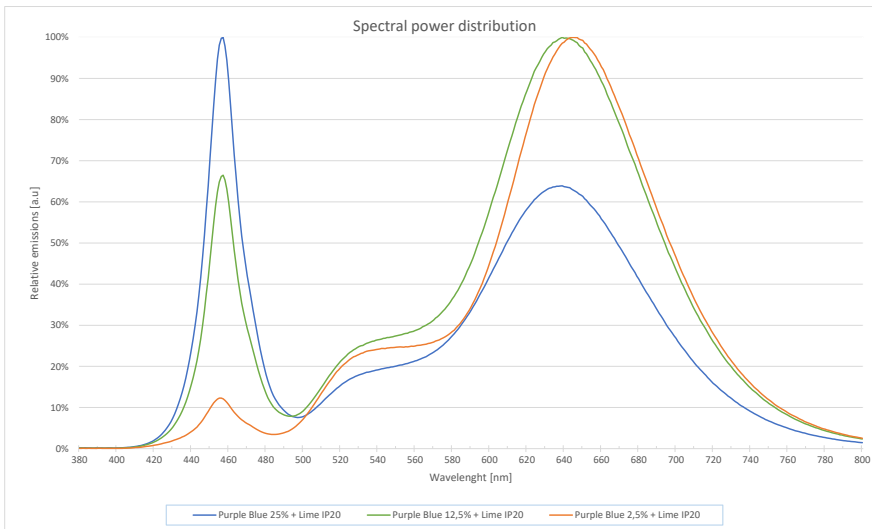

AluLED IP67 Horticulture

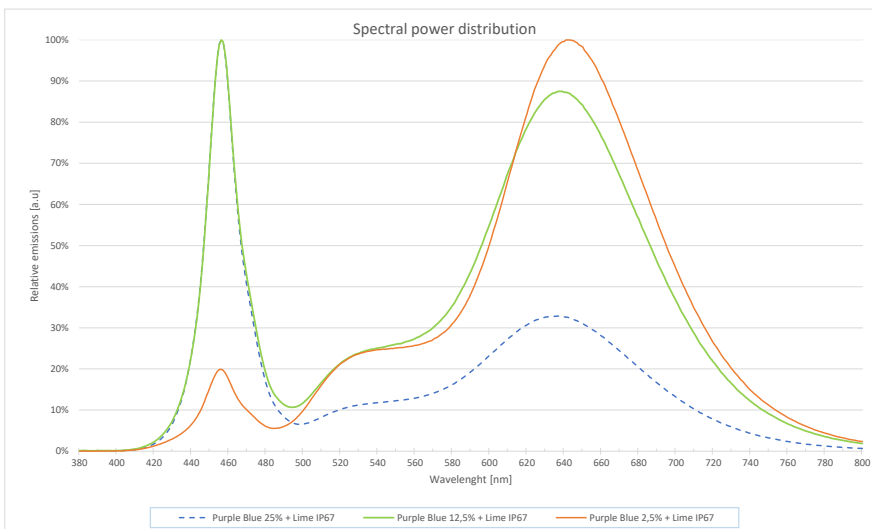

AluLED IP20/IP67 Horticulture

EasyConnect Cable for AluLED

Max. permissible current: 3 A

Number of strands: 2/4

(Strand diameter: 0.35 mm²/22 AWG)

For monochrome modules with 2 strands

Ref. No.: 543426 25 cm, feed cable for power supply

Ref. No.: 543427 50 cm, PCB to PCB connector

For RGB modules with 4 strands

Ref. No.: 543428 25 cm, feed cable for power supply

Ref. No.: 543429 50 cm, PCB to PCB connector

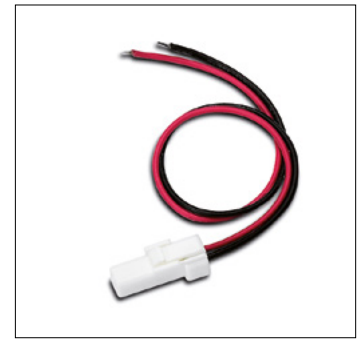
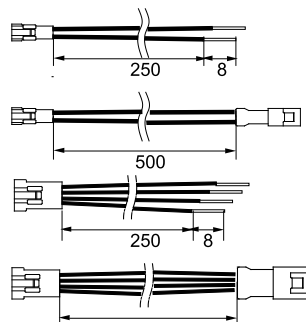

Shrink caps

For sealing exposed connection wires

(Strand diameter: 0.35 mm²/22 AWG)

Adhesive coating on the inside

Ref. No.: 571150 transparent

Ref. No.: 571151 black

Magnetic holder for AluLED

For easy fixation with springs and magnet

(scope of supply: 2 pcs.)

Ref. No.: 143208



Safety Instructions

- AluLED products may only be installed and commissioned by authorised and qualified staff.
- Please read these instructions carefully prior to installing and commissioning the system since this is the only way to ensure safe and proper system operation. You are recommended to keep these instructions in a safe place for possible future reference.
- Any work undertaken on a device must only be performed after disconnection from the mains.
- Relevant safety and accident prevention measures must be observed.
- Products must never be improperly opened since electrical voltage poses a risk to life. Repairs must only be performed by the manufacturer.
- Connecting feeder/supply lines to external voltage, e.g. 230 V mains voltage, can destroy individual system components.

Mounting

1. Screw the mounting clips firmly to the substrate.
 2. Click module into the mounting clips.
- Mounting clips (brackets) are used to attach AluLED modules to a solid, load-bearing substrate. The mounting clips must be attached to the substrate using screws. The space left between the mounting clips must ensure the module neither bends nor bows. Once properly mounted, the AluLED module must be firmly enclosed by the mounting clips.
 - The module can be installed any way up, but vertical wall mounting could lead to the module slipping out of the clips.
 - Sufficient clearance must be left to other neighbouring objects to allow for the longitudinal thermal expansion of the module.
 - To prevent corrosion, contact with base metals, aggressive fluids and gases must be avoided. Operation in environments that are chemically enriched with (aggressive) chemical substances can impair functionality and can even result in total module failure. Detailed information as well as examples of hazardous environments and chemical substances can be found in the document "Chemical Incompatibilities Affecting LEDs", published by Vossloh-Schwabe Deutschland (www.vossloh-schwabe.com).

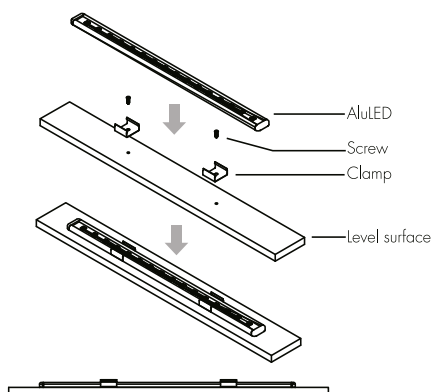

Die Werte in diesem Datenblatt können sich aufgrund technischer Innovationen verändern und werden ohne gesonderte Benachrichtigung vorgenommen.

AluLED IP20/IP67 Horticulture

Installation Instructions

1. When using several modules, the connector of a feed-out line must be attached to the connector of the following module's feed-in line.
2. The final feed-out line must be protected against humidity and water ingress with a connector.
3. Connect control gear's feed-in line to the control gear unit (48 V constant current driver with a constant output voltage of 48 V \pm 5%).
4. Check the polarity of the control gear's feed-in line (red + /black -).
5. Attach the control gear's feed-in line to the connector of the (first) AluLED module's feed-in line.
6. Calculate the total power uptake of the connected AluLED IP20 modules and compare the value with the data supplied for the connected control gear. Should the control gear's permissible total power uptake be exceeded, the equipment needs to be replaced with an adequately rated control gear unit.
7. Connect the control gear to the power supply in accordance with the installation instructions.

- Each AluLED module is fitted with a pre-assembled feed-in line with a connecting terminal as well as with a feed-out line with a connector for looping the supply voltage through to the next AluLED module.
- Should this not be necessary, the spare connector must be protected against the ingress of humidity.
- Alternatively, the connecting terminal can be removed and the exposed connecting wires sealed using shrink caps that are internally coated with adhesive (Ref. No.: 571150 (transparent) or 571151 (black)).
- If only one such shrink cap is used to seal both connecting wires, care must be taken to ensure the wires are of differing lengths to prevent the internal metal conductors from touching one another.
- The connecting terminals and connectors of the pre-assembled connecting leads prevent any reversal of polarity. Only the polarity of the control gear's requisite feed-in line (Ref. No.: 543426) can be reversed when connecting it to the control gear.
- Prior to commissioning, care must be taken to ensure the polarity of the control gear's feed-in line is correct. The red cable is "+" and the black cable is "-".
- A 48 V constant current driver with a constant output voltage (48 V \pm 5%) must be used for control gear purposes. To ensure safe operation this 48 V constant current driver should also be fitted with protection against overvoltages, short-circuiting and over-heating.
- The maximum 3 A current load on the voltage supply line, the control gear's feed-in line and the extension lead must not be exceeded. The resulting maximum number of AluLED modules that can be connected is additionally dependent on the maximum output current of the 48 V constant current driver with a constant output voltage as well as the voltage drop caused by the AluLED modules and their leads.

Further Information

- If the distance between the control gear and the (first) AluLED IP20 module is too great to be bridged using the feed-in lines of the control gear and the AluLED module, a VS extension lead (Ref. No.: 543427) must be used to close the gap.
- Should an extension lead additionally be used to connect AluLED modules that are farther away, the unavoidable electrical resistance of the extension lead will cause a more pronounced voltage drop, which in turn can impair the functionality of the AluLED modules. AluLED modules are designed for operation with a constant voltage of 48 V \pm 5%.

Complies to following standards

EN 62031:2008 / A1:2013 / A2:2015
LED modules for general lighting – Safety specifications

EN 60529:1991 / A1:2000 / A2:2013
Degrees of protection provided by enclosures (IP Code)

Die Werte in diesem Datenblatt können sich aufgrund technischer Innovationen verändern und werden ohne gesonderte Benachrichtigung vorgenommen.